

Cone Beam 3D Imaging
NewTom
what's next



Making Your Life Better.

BU Medical Equipment

Sede legale ed amministrativa
Headquarters

CEFLA s.c.

Via Selice Provinciale 23/a ▪ 40026 Imola ▪ Italy
t. +39 045 8202727 ▪ 045 583500
info@newtom.it

**Stabilimento
Plant**

Via Bicocca, 14/c
40026 Imola - Bo (Italy)
tel. +39 0542 653441
fax +39 0542 653601

newtom.it



01/2024 NDCSGB221500
According to the standards in force, in extra-EU areas the availability and specifications of some products and/or characteristics may vary. Please contact your local distributor for further information. Pictures are for illustration purpose only.

NewTom DCiS DIRECT.VISION

WIRELESS INTRAORAL DC SENSOR



Cone Beam 3D Imaging
NewTom
what's next

THE FIRST DIRECT CONVERSION SENSOR.

Advanced technology
for top-class image
quality.
A sensor as brilliant
as NewTom.

NewTom DCiS is the most advanced wireless intraoral sensor as it integrates direct conversion (DC) technology. Thanks to this innovative 2D imaging system, NewTom DCiS is able to deliver very high definition images at low X-ray doses, for extremely accurate diagnoses.

While ensuring patient comfort, NewTom DCiS optimises the workflow for operators and, thanks to the Infinity system, transfers data via Wireless technology quickly and effectively, reducing energy consumption.

As cables are wear parts, its wireless design extends the life of the device, as well as improving operating efficiency and patient comfort.



Ultra HD

NewTom DCiS produces sharp and detailed images, which are then ideally processed and displayed by the NNT software.



COMFORT

The shape and size of the sensor make it easy to introduce into the patient's mouth minimising discomfort.



INFINITY

Data transmission to the docking station connected to the PC is done via Wireless, without the need of cables and with maximum flexibility.



ROBUSTNESS

The outer casing and internal components are designed to be resistant to impacts, falls and compression, as well as ingress of dust and liquids.



Ultra HD IMAGING WITH THE DIRECT CONVERSION SENSOR.

Raising the bar of imaging thanks to DC technology and NNT software features.

NewTom DCiS is the first intraoral sensor on the market capable of integrating direct conversion technology - designed to deliver very high resolution images for even the most complex dental morphologies.

The excellent level of contrast and sharpness is completed by the added functions of the NNT software which, with its new advanced filters, allows diagnostic details to be enhanced.

DC TECHNOLOGY

Normal sensors are sensitive to visible light, and it is therefore necessary to convert X-rays through a scintillator so that they can be captured by the sensor.

With DC technology, however, the sensor receives and processes X-rays directly, without any intermediate conversion. In this way, high resolution images are obtained with an excellent level of contrast, and with very low X-ray doses safeguarding patient health.

Moreover, the sensor is stronger and less bulky, since unlike conventional technology intraoral sensors it does not contain traditionally fragile components.

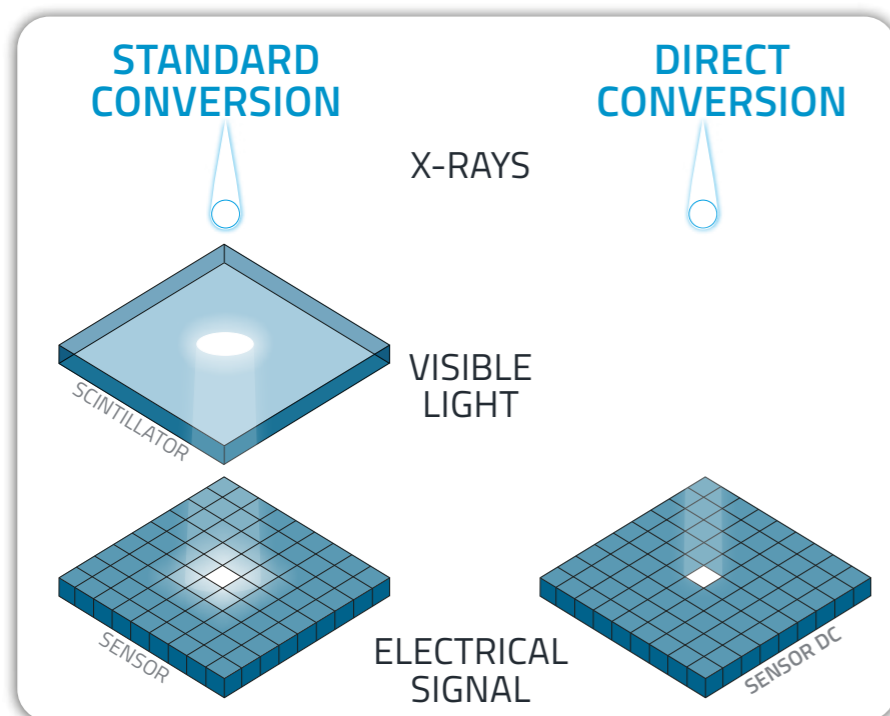

MAXIMUM SHARPNESS

NewTom has always worked to offer the highest image quality standard for reliable diagnoses.

DC technology applied to the sensor delivers X-ray imaging with a very high degree of detail, allowing dentists to carefully evaluate the resulting clinical picture.

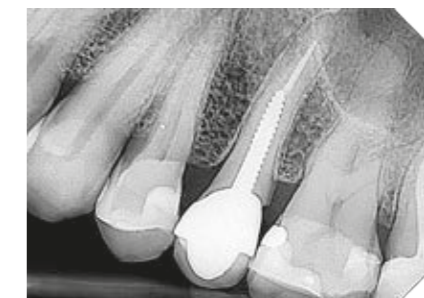

THE ADVANTAGES OF NEWTOM DCiS

A difference clearly emerges from the comparison between X-ray images obtained with traditional sensors and those obtained with direct conversion technology: NewTom DCiS dramatically improves contrast and sharpness enhancing the visibility of conditions that otherwise would not always be clearly diagnosable.



DC



STD

NEWTOM ADAPTIVE MULTIVISION

The NNT software provides the dentist with ApT (Adaptive picture Treatment) filters in Adaptive MultiVision mode and suitable for different clinical needs.

You can select which filters to use from pre-set families or define customised ones based on individual diagnostic or visual preferences.

In particular, it is possible to choose to preserve the visibility of soft tissues, keeping unaltered any areas at risk of image darkening. It is also possible to increase the contrast, if the desired level cannot be obtained for anatomical reasons, or due to the radiological parameters set. A default filter has the task of balancing noise, contrast and grey scale, while an additional filter enhances the details of the anatomical area examined.

Finally and exclusively for the bitewing examinations, the caries revealing filter highlights the presence of interproximal caries.

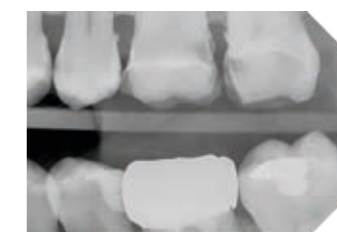

DEFAULT



CARIES REVEALING



DEFAULT

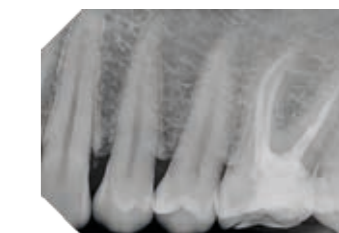

HIGH DETAILS



SOFT TISSUE PRESERVING

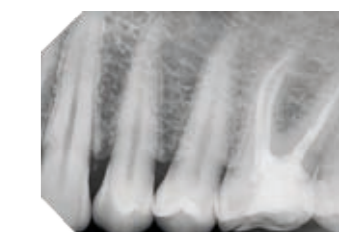

HIGH CONTRAST

SMART DESIGN.

Comfort for the patient and user-friendliness for the operator: NewTom DCiS is a small engineering masterpiece.

Every detail of the NewTom DCiS sensor has been designed to improve global ergonomics and to reduce any discomfort felt by the patient. The rounded corners are less invasive, and the absence of a cable prevents further discomfort. A set of optional accessories specially designed for this sensor allows correct alignment and positioning, in addition to minimising the irradiated area. NewTom DCiS communicates directly with the docking station via Wireless technology, combining energy savings and maximum flexibility of use.

DOCKING STATION

The docking station has the purpose of receiving data transmitted via Wireless from the sensor and forwarding them, via USB cable, to the PC or laptop of the clinic. Data transfer and processing takes just a few seconds, so the X-ray image is immediately available on the NNT software. The docking station also acts as a housing and charging base for the sensor when it is not in use.



WALL FIXING

Depending on working requirements and space arrangement, the docking station can be placed on a worktop, but also fixed to the wall using a special mounting kit (optional), so as to free up useful space on your worktop.



ERGONOMICS

The sensor (Size 2) has rounded edges to prevent unnecessary patient discomfort. The active area is wider than in traditional sensors, so virtually the entire footprint can be used. This being direct conversion technology, the sensor is thinner and allows the rechargeable battery to be contained in a small space. The LED on the back indicates the different states of the device, which is always visible to the user as it can be displayed on the user's PC screen via iCapture.



STRENGTH

The outer casing and internal components are sturdy and withstand impacts and compression. Unlike traditional sensors, NewTom DCiS does not have easily breakable internal components like scintillators. It is also certified with an IP67 degree of protection against the ingress of dust and liquids.

POSITIONING

The alignment system has been specially designed for the wireless sensor and will not add to the footprint, while ensuring patient comfort as well as making positioning easier. The system also allows the X-ray source to be brought as close as possible to the patient's face so as to avoid unnecessarily exposing other areas to radiation.



NEWTOM'S SIGNATURE WORKFLOW.

Cable-free NewTom DCiS guarantees maximum flexibility and flawless results.

NewTom DCiS combines two technologies, direct conversion and Wireless transmission.

The result is a highly performing sensor with a small footprint, which uses low doses of X-rays to produce a high resolution image in mere moments and transmit data in wireless mode.

WIRELESS INFINITY

With NewTom DCiS, the workflow is divided into four simple steps: positioning, shooting, viewing on PC or laptop and sharing. All this by being able to operate from any location without the limits imposed by a cable. The sensor integrates seamlessly with NNT software, which offers all the necessary tools to navigate through images, calibrate and store them.



01
POSITIONING



02
SHOOTING



03
VIEWING



04
SHARING



IMMEDIATE DISPLAY

NewTom DCiS allows X-ray images to be viewed almost instantly for immediate evaluation and communication with the patient.

CONFIGURATIONS

The NewTom DCiS system is highly flexible and perfectly functional for multi-room surgeries. Different configurations are possible, based on specific needs.

SCENARIO A

Each room has its own docking station, and a sensor is paired with each docking station. Data transmission is therefore of the 1 to 1 type and simultaneous transmission is also a possibility.

SCENARIO B

Each room has its own docking station, and all the docking stations receive data from one sensor. The sensor can interact with only one docking station at a time, as long as the user always remembers, before use, to place the sensor on the docking station to which the images obtained should be sent.

SCENARIO C

Multiple sensors can be paired with a single docking station, but data transmission will always take place between a single docking station and the last sensor paired with it.



in according to
EN ISO/IEC 17065:2012



NNT: CERTIFIED SOFTWARE

NNT has been granted the ISDP® 10003 international scheme for data protection certification, to assess compliance with the European Regulation 2016/679 concerning the protection of individuals with regard to the processing of personal data.

TECHNICAL SPECIFICATIONS.

DIMENSIONS

Sensor size	2
Sensor footprint (mm)	43.4 mm - 1.7" (height) x 29.5 mm - 1.1"(width)
Sensor thickness (mm)	5.2 mm - 0.2" (9.2 mm - 0.3" considering the battery housing hub)
Active area (mm)	35.1 mm - 13.8" x 24.7 mm - 0.9"
Docking station (mm)	100 mm - 3.9" (diameter) x 62 mm - 2.4" (height)
USB lead length	2 m (supplied to connect docking station to PC/laptop)

IMAGE ACQUISITION

Pixel matrix	1350 x 950 (1,282,500 pixel)
Detector	Single-crystal direct-conversion silicon / CMOS
MTF (Modulation Transfer Function)	> 70% @ 5 lp/mm, > 40% @10 lp/mm
Exposure parameters	0.1-0.5 s, 60-70 kV, 6/8 mA, 20 cm (8") cone
Wireless image transmission time	Less than 10 s under optimal working conditions

SENSOR TECHNICAL SPECIFICATIONS

Internal battery	Rechargeable lithium ion (capacity 19 mAh)
Degree of protection	IP 67 (Guaranteed against liquid or dust infiltration)
Integrated RAM memory	4 MB (maximum 1 preservable image)
Image transmission technology	Wireless
Wireless operating distance	Up to 2.5 m from docking station
Compatibility with X-ray generators	Wall-mounted or cart (both AC and DC): 2-10 mA and 60-70 kV. Portable: 2-10 mA and 60-70 kV.
Complete recharge time	3.5 h (allows acquisition of 140* consecutive images, with a 40 s pause between two examinations)
Minimum advisable recharge time	15 minutes (allows acquisition of 19* consecutive images, with a 40 s pause between two examinations)

SOFTWARE

Acquisition software (for PC)	iCapture with dedicated filters for third party software
Image management software (for PC)	NNT (complies with ISDP®10003:2020 as per EN ISO/IEC17065:2012 certificate number 2019003109-2)
Supported protocols	DICOM 3.0, TWAIN, VDDS
DICOM nodes	IHE compliant (Print; Storage Commitment, SR document; WorkList; MPPS; Query/Retrieve)

MINIMUM SYSTEM REQUISITES

Supported operating systems	Microsoft® Windows® 10 (Professional 64 bit) and 11
Processor	6th generation Intel i5 or equivalent
RAM	At least 4 GB of RAM and 100 GB of space on hard disc
Display	Resolution of 1920x1080 pixel and 24bit RGB Full HD (high definition)

COMMUNICATION INTERFACES

Docking station connection port	USB-C
PC/laptop connection port	USB-A
Power supply	+5V ± 10%
Input power	2,5 W

* Values susceptible to a reduction in performance due to effective battery life (the battery must only be replaced by qualified technicians).

Specifications subject to change without prior notice.

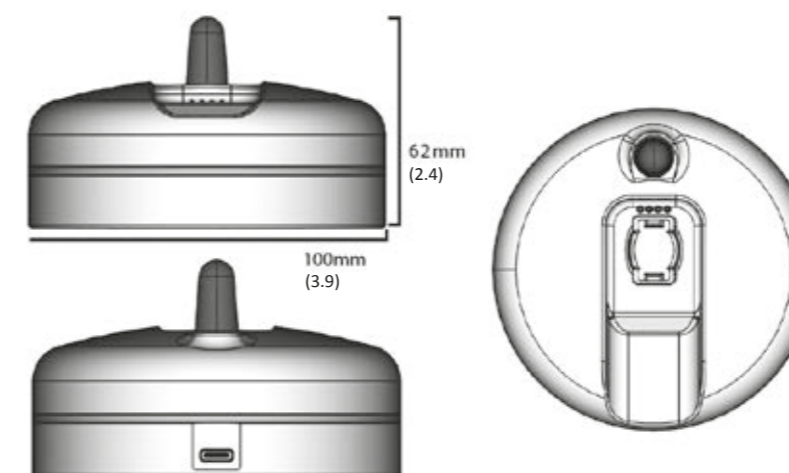

Dimensions in millimeters
(dimensions in inches)

